

Connettore MB/moduli

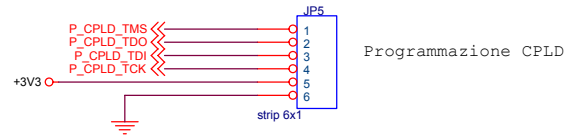

Programmazione CPLD



Sonda 10x
(9Mohm,
10-12pF)

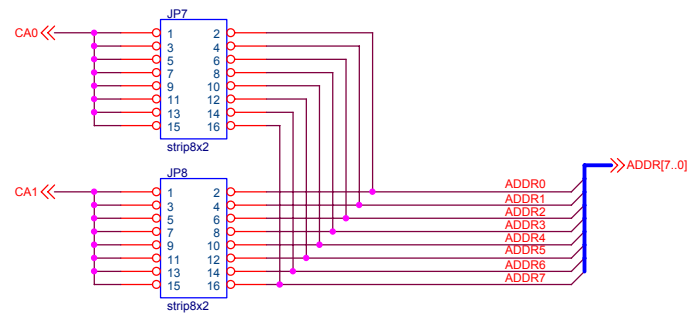

Selezione indirizzo

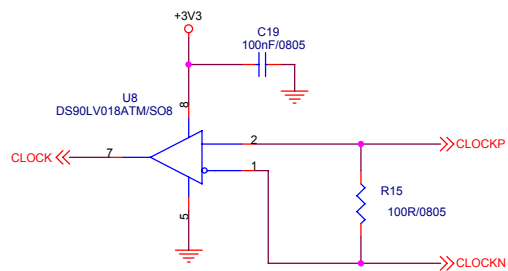

Resistenza di
terminazione -
montare solo sul
modulo piu' lontano

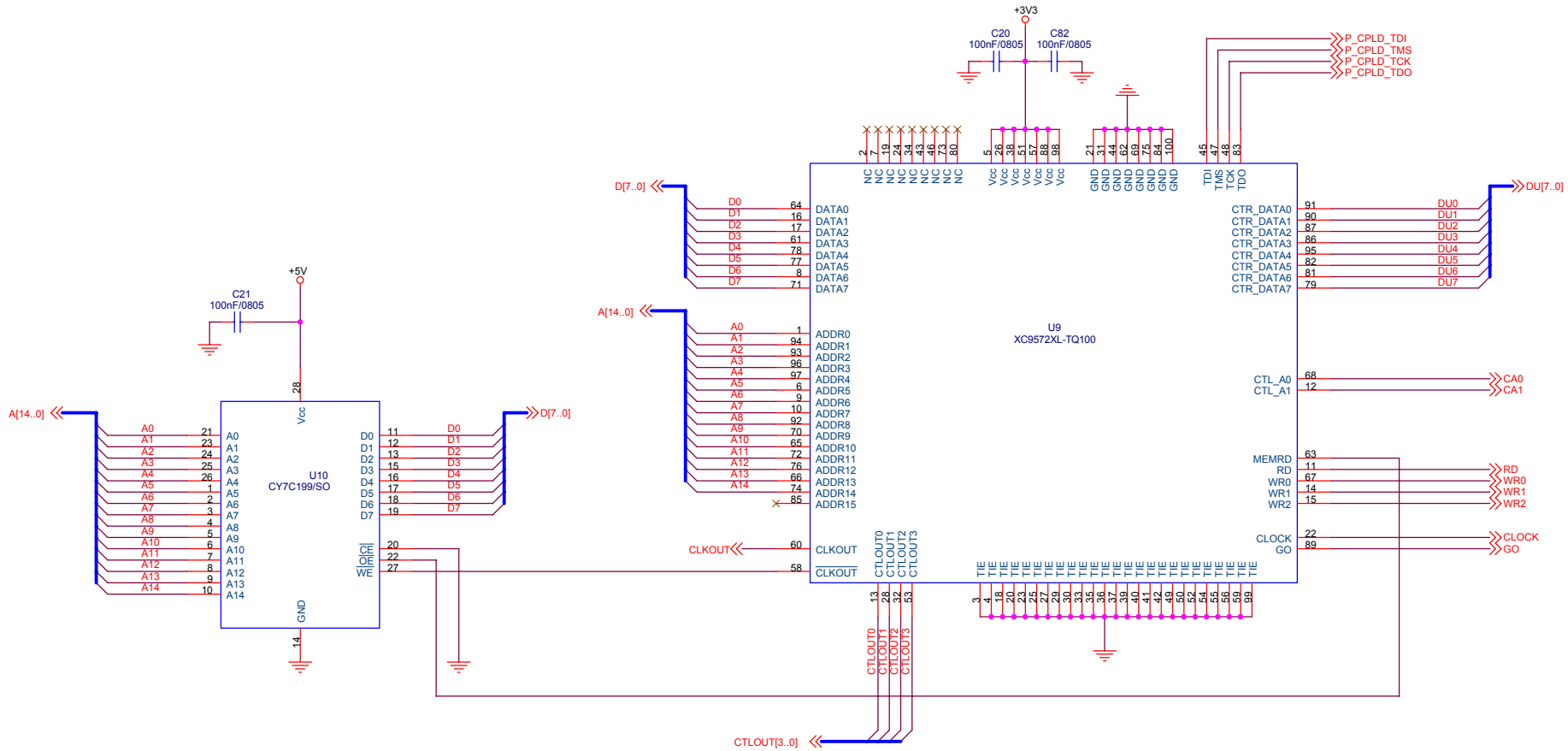

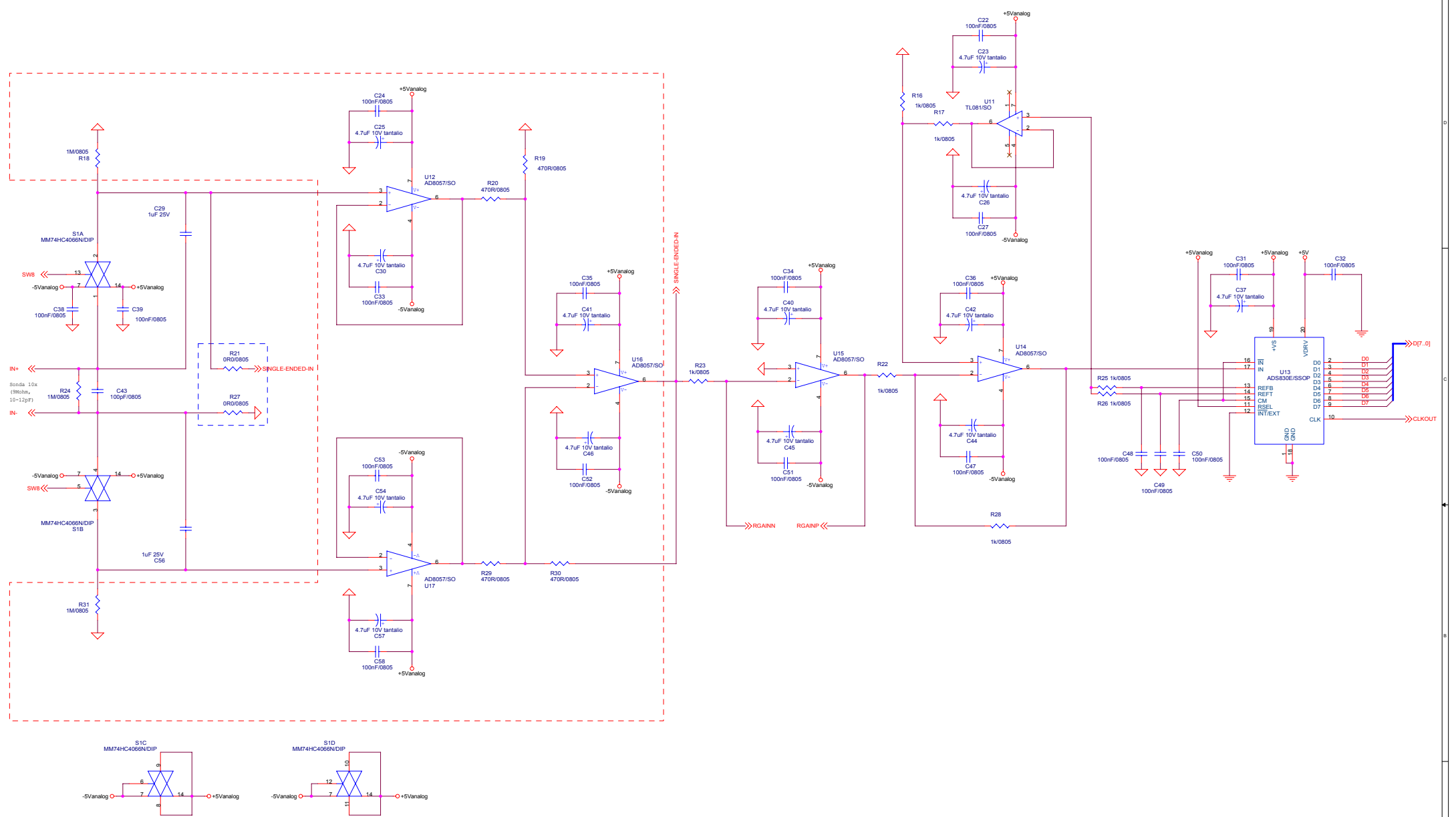

Montare solo i componenti della zona rossa tratteggiata (differenziale) o quelli della zona blu tratteggiata (single ended)

