

Connettore MB/moduli

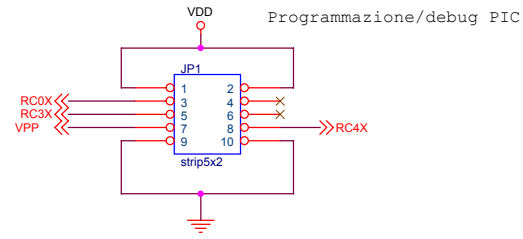

Programmazione/debug PIC

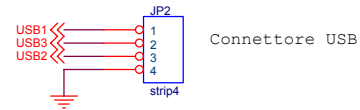

Connettore USB

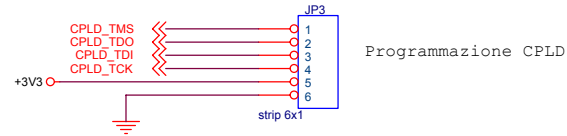

Programmazione CPLD

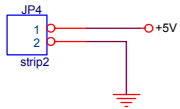

Alimentazione (5V 1A=)

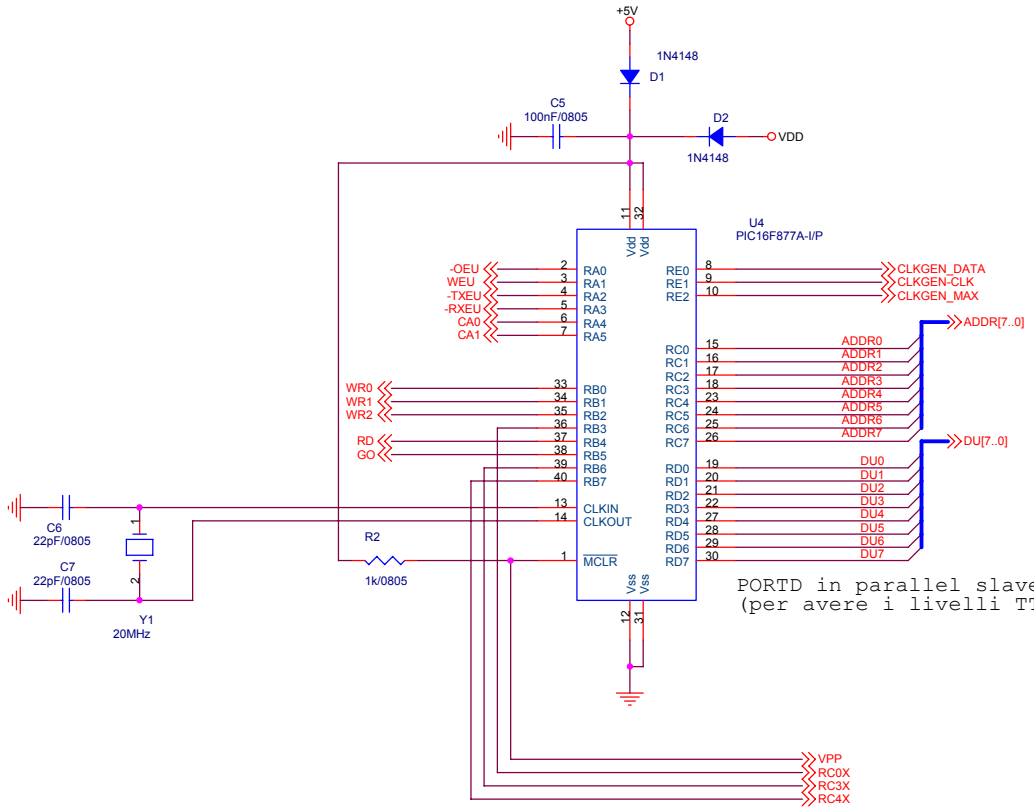

PORTD in parallel slave mode  
(per avere i livelli TTL)!

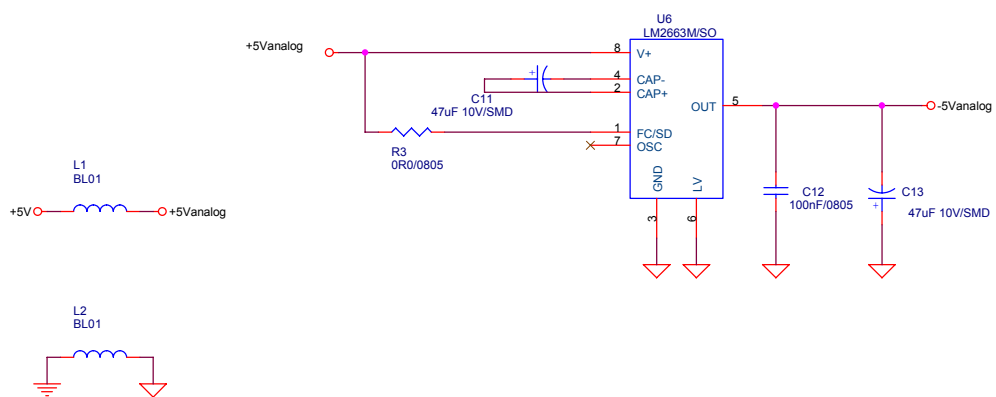
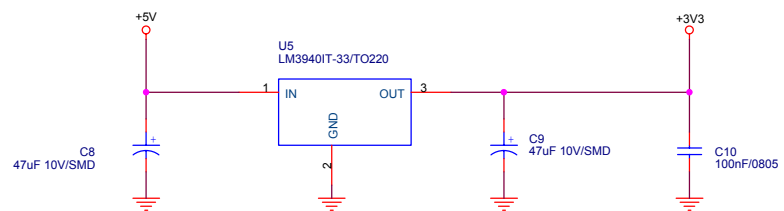

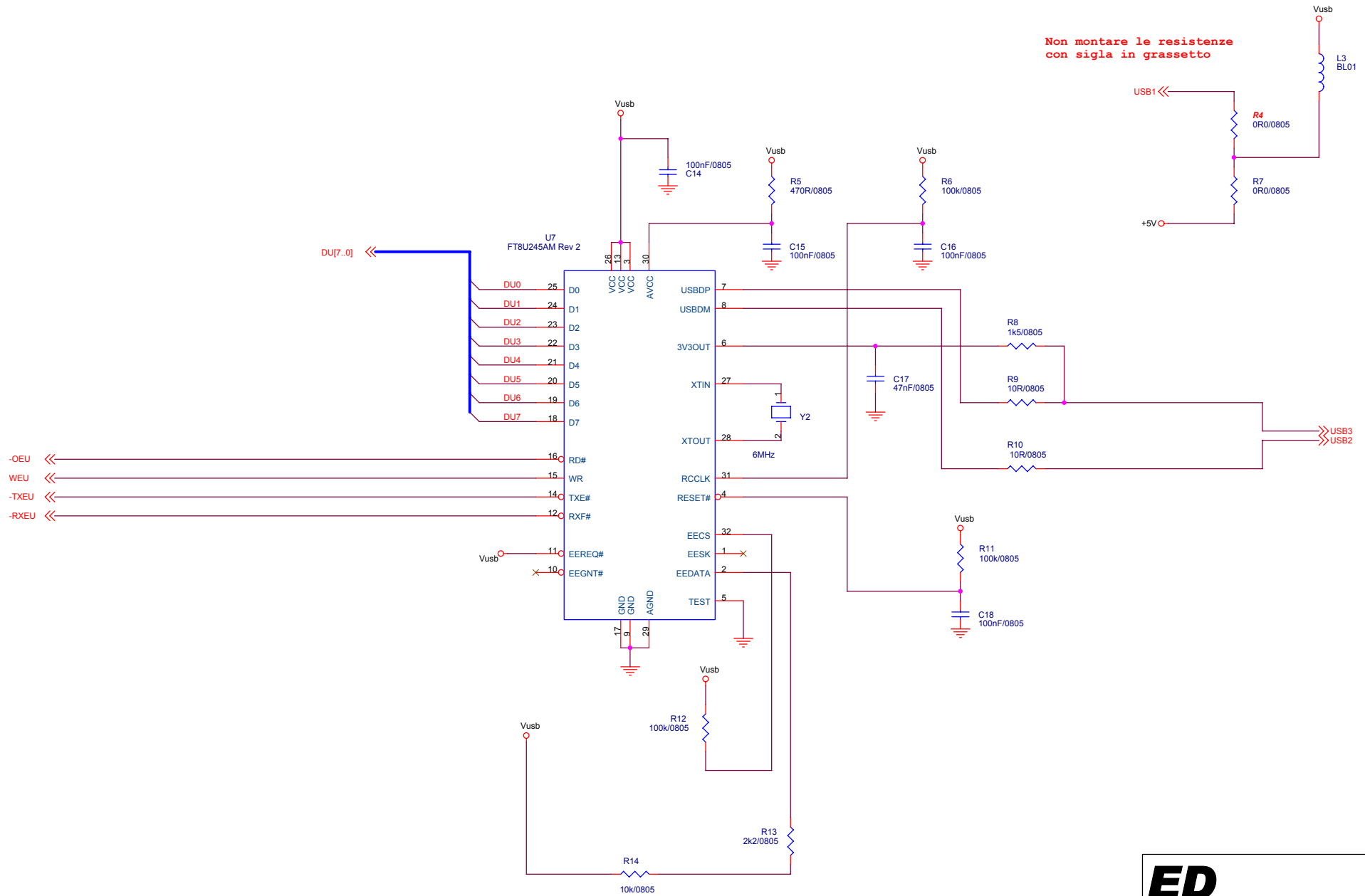

Non montare le resistenze  
con sigla in grassetto

<b>ED</b> Embedded Devices		Designer: Lorenzo Lutti	
		Title USB	
Size A3	Project DSO	Revision 1	
Date: Sunday, April 27, 2003		Sheet 9 of 9	